

ELECTRIC HEIGHT ADJUSTABLE DESK FRAMES

可调高度的电动台架

قواعد مكاتب يمكن ضبط ارتفاعها كهربائيا





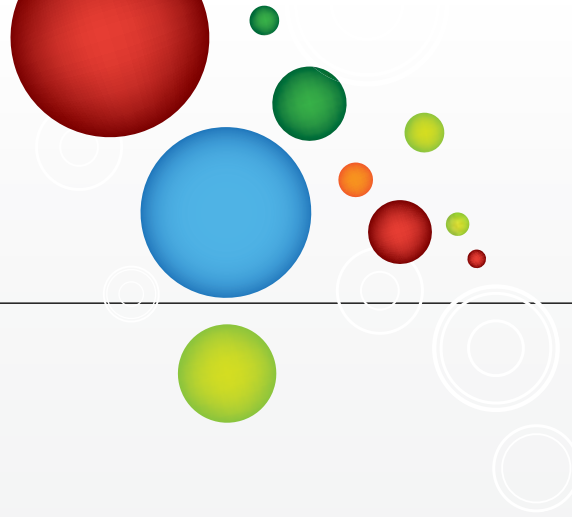

ConSet

501-49



501-49 is an elegant and stylish desk frame with round columns and designed with a telescopic cross bar that can be adjusted in intervals of 10 cm. Using the proven ConSet driveshaft single motor technology in an open frame design gives a maximum capacity on the 2-column frame of 100 kg and 90 kg for the 3-column frame. Available in silver, black and white with inner columns in chrome. Delivered in one box for the 2-legged frame and in two boxes for the 3-legged frame. Easy to ship and easy to assemble.
[See specifications on pages 18-19.](#)

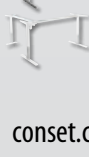

Frames	Item no.	Colour	Width / Depth
	501-49 7S176	Silver	116-176 cm
	501-49 7B176	Black	116-176 cm
	501-49 7W176	White	116-176 cm
	501-49 7S176-196A	Silver	126-176 cm / 136-196 cm
	501-49 7B176-196A	Black	126-176 cm / 136-196 cm
	501-49 7W176-196A	White	126-176 cm / 136-196 cm









501-11 is nothing less than a mechanical masterpiece. The frame is a true workhorse and the BOSCH motor provides the ultimate reliability. In the price you get a modesty panel and two slim cable runs via the top support rails.

501-11 is one of our best selling models, you can be sure that with **501-11** you get nothing less than an exceptional well proven heavy duty electric height adjustable desk. Maximum frame capacity is 150 kg (138H 100 kg).

See specifications on pages 18-19.



Frames	Item no.	Colour	Width / Depth
	501-11 1S138H	Silver	138 cm
	501-11 1B138H	Black	138 cm
	501-11 1S116	Silver	116 cm
	501-11 1B116	Black	116 cm
	501-11 1S156	Silver	156 cm
	501-11 1B156	Black	156 cm
	501-11 1S196	Silver	196 cm
	501-11 1B196	Black	196 cm
	501-11 1S156-156A	Silver	156 cm / 156 cm
	501-11 1B156-156A	Black	156 cm / 156 cm
	501-11 1S196-196A	Silver	196 cm / 196 cm
	501-11 1B196-196A	Black	196 cm / 196 cm

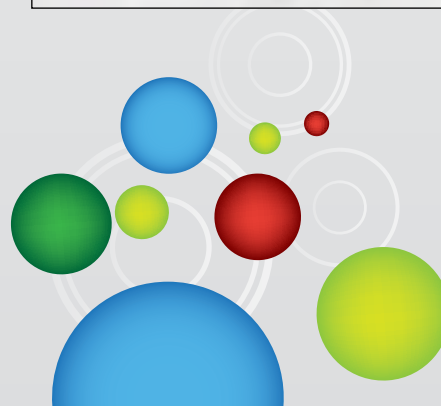

501-25

501-25 is a beautifully designed table which is extremely functional and covers all the basic needs for a height adjustable table. It is very stable with 80 kg as the maximum frame capacity on the 2-column frame.

See specifications on pages 18-19.



↑
66-116 cm
↓



Frames	Item no.	Colour	Width / Depth
	501-25 7S084	Silver	84 cm
	501-25 7S133	Silver	133 cm
	501-25 7S152	Silver	152 cm
	501-25 7S172	Silver	172 cm
	501-25 7S152-115A	Silver	152 cm / 115 cm
	501-25 7S152-152A	Silver	152 cm / 152 cm
	501-25 7S 172-172A	Silver	172 cm / 172 cm



Build 120° frames with
501-2GS. See conset.com

501-29 is perfect for taller individuals. At its full height the frame measures 130 cm. Extremely strong and stable it has a maximum frame capacity of 100 kg on the 2-column frame which comes in four standard widths. Plus there are 2 designs of 3-column frame that have a maximum frame capacity of 90 kg.

See specifications on pages 18-19.



Frames	Item no.	Colour	Width / Depth
	501-29 7S084	Silver	84 cm
	501-29 7S133	Silver	133 cm
	501-29 7S152	Silver	152 cm
	501-29 7S172	Silver	172 cm
	501-29 7S152-115A	Silver	152 cm / 115 cm
	501-29 7S152-152A	Silver	152 cm / 152 cm
	501-29 7S172-172A	Silver	172 cm / 172 cm



501-27

501-27 is suitable for children through to adults. The desk frame height range is 54 to 119 cm. The extra low starting height means the desk can be ideal for the whole family to sit or stand whilst working at home or in schools and colleges. The shallow depth of the frame also means it is suitable for shallow tops and benches from 60 to 100 cm deep. Removable top bracket allows for easy installation of keyboard support. The maximum frame capacity is 100 kg.

See specifications on pages 18-19.



Build 120° frames with **501-2GS**. See conset.com

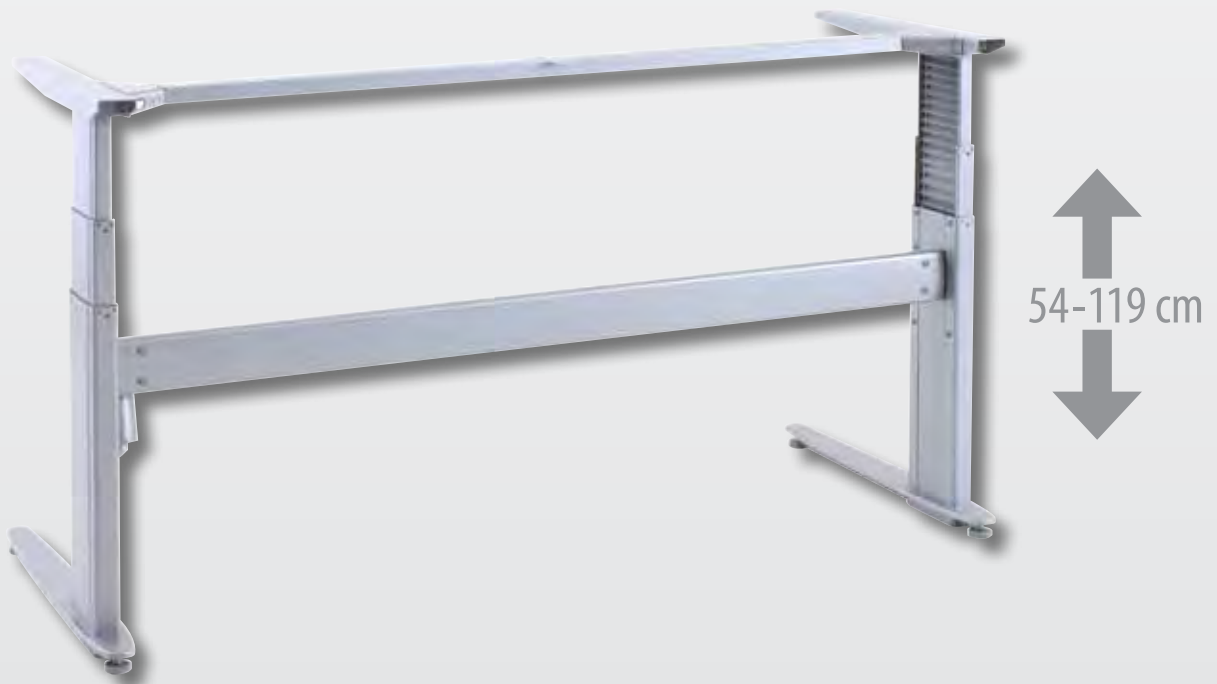

Frames	Item no.	Colour	Width / Depth
	501-27 7S084	Silver	84 cm
	501-27 7S133	Silver	133 cm
	501-27 7S152	Silver	152 cm
	501-27 7S172	Silver	172 cm
	501-27 7S152-115A	Silver	152 cm / 109 cm
	501-27 7S152-152A	Silver	152 cm / 146 cm
	501-27 7S172-172A	Silver	172 cm / 166 cm



501-32 sets a new standard for electric height adjustable desks. This desk frame has interchangeable cross rails that work with 501-25, 501-27 and 501-29. A great option for stocking dealers. It can accommodate table tops that are 60 to 100 cm deep. Extremely stable with a maximum frame capacity of 80 kg on the 2-column frame. Optional high quality locking castors are available. See specifications on pages 18-19.



Frames	Item no.	Colour	Width / Depth
	501-32 7S084	Silver	84 cm
	501-32 7S133	Silver	133 cm
	501-32 7S152	Silver	152 cm
	501-32 7S172	Silver	172 cm
	501-32 7S152-115A	Silver	152 cm / 109 cm
	501-32 7S152-152A	Silver	152 cm / 146 cm
	501-32 7S172-172A	Silver	172 cm / 166 cm





501-19 Basic

501-19 Basic is a highly functional and versatile single column desk base. Add castors and our rechargeable battery pack for complete mobility. Use as a free standing desk or join multiple units together for a unique and distinctive setup. With a maximum frame capacity of 100 kg, stability and functionality are key attributes for this series.

See specifications on pages 18-19.



Frames	Item no.	Colour	Width
	501-19 7S095	Silver	95 cm
	501-19 7B095	Silver	95 cm

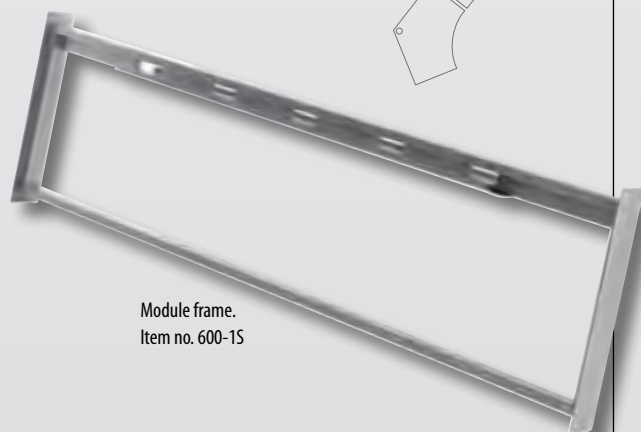
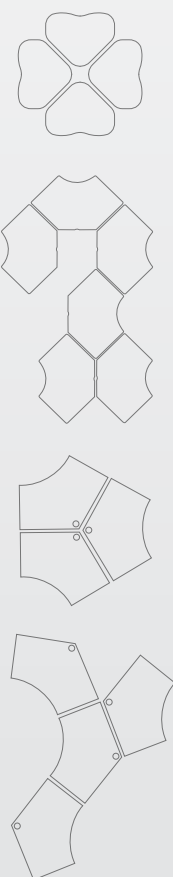

Module frame.
Item no. 600-1S

Module frame for groups of 4 to 6 columns, creating a bench for people with individual height adjustment. Maximum space around the table. Perfect for smaller work stations or project desks.



501-19 Design

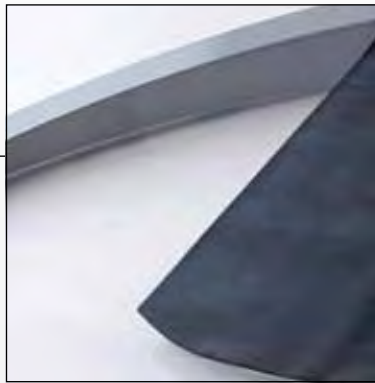



501-19 Design is a very stylish single column frame with a unique look. It is well suited as a stand-alone workstation or can be set up in groups allowing for a unique design approach. The elegant crescent shaped base provides excellent stability.

Maximum frame capacity is 100 kg.

See specifications on pages 18-19.



66-118 cm



Frames	Item no.	Colour	Width
	501-19 7S120	Silver	120 cm
	501-19 7B120	Black	120 cm



501-19 Center

501-19 Center has a compact base and a symmetrical design which allows for it to be used from either side. Like the Basic model it can be fitted with optional heavy duty locking castors and our rechargeable battery. Not being tied to a wall outlet lets you move your workstation to where it makes sense for you. Now that is clever. Maximum frame capacity is 100 kg.

See specifications on pages 18-19.

Frames	Item no.	Colour	Width
	501-19 7S060	Silver	60 cm
	501-19 7B060	Black	60 cm





Flexibility:
Swivel and lockable castors.



Mobility:
Rechargeable battery

As experts in the field of single-column height adjustable desks, we must admit that we are quite proud of this series. **501-7** is a small computer desk with many uses. An excellent electric height adjustable desk at possibly the lowest price on the market is the ConSet reality. Built-in locking castors provide a mobile desk frame that can be used as a stand-alone unit or for group setups. The maximum frame capacity of 50 kg allows the frame to be used with a variety of top designs.

See specifications on pages 18-19.

Frames	Item no.	Colour	Width
	501-7 7S	Silver	94 cm
	501-7 7B	Black	94 cm

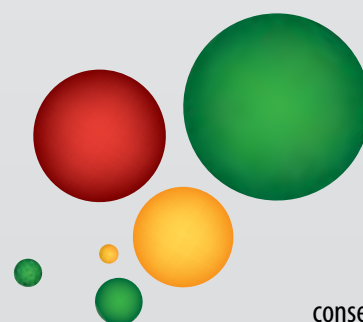
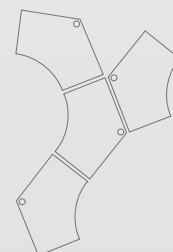
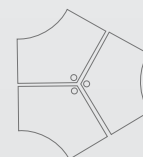
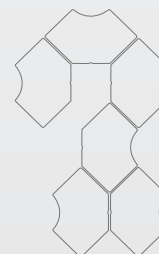

501-19 Wall



501-19 Wall creates a functional and attractive workstation. The wall brackets attach easily to the leg enabling you to secure the frame to a wall.

Place the column directly on the floor or raise it a few centimeters so the floor can be cleaned.

This is especially useful in medical settings. Without the need for floor brackets maximum space can be achieved beneath the work surface. The sturdy frame has a maximum capacity of 100 kg.



See specifications on pages 18-19.

Frames	Item no.	Colour	Width
	501-19 7SWS	Silver	90 cm
	501-19 7BWS	Black	90 cm
	501-23 7SWS2	Silver	Min. 180 cm
	501-23 7BWS2	Black	Min. 180 cm
	501-23 7SWS3	Silver	Min. 270 cm
	501-23 7BWS3	Black	Min. 270 cm



501-7 Wall can be used similarly to the 501-19 Wall yet it provides a very economical solution for an electric height adjustable workstation. The brackets are sturdy and simple to mount and the frame offers a maximum capacity of 50 kg.

See specifications on pages 18-19.

Frames	Item no.	Colour	Width
	501-7 7SWS	Silver	75 cm
	501-7 7BWS	Black	75 cm

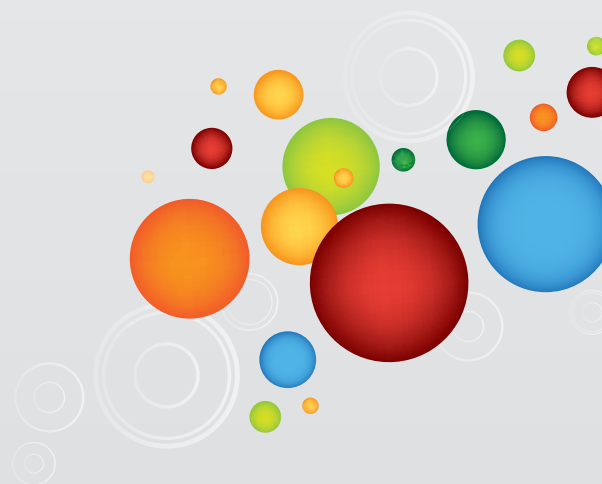

501-15 is very economical. The two leg version can simply have the third leg kit added for L shape tops. Both are adjustable in length according to the width of the front panels. The frame is designed aimed at desk manufacturers to buy as a kit but to add their own top and front panel creating a desk to combine with their other products.

No front panel is included and this is essential for the frame to work, a drawing for the design of the front panel is included.

With the size flexibility and easy two or three leg option series **501-15** makes a very cost effective and versatile range to stock for any furniture manufacturer.

Maximum frame capacity 65 kg for the two leg frame and 60 kg for the three leg frame.

See specifications on pages 18-19.

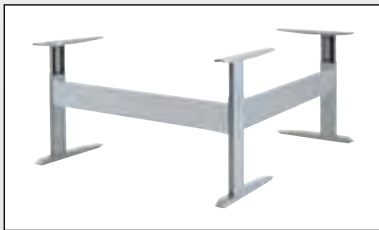

Frames	Item no.	Colour	Width / Depth
	501-15 7SXXX	Silver	Up to 180 cm
	501-15 7WXXX	White	Up to 180 cm
	501-15 7SXXX + 501-15 XSXXXA	Silver	Up to 180 cm / Up to 180 cm
	501-15 7WXXX + 501-15 XWXXXA	White	Up to 180 cm / Up to 180 cm

66-118 cm

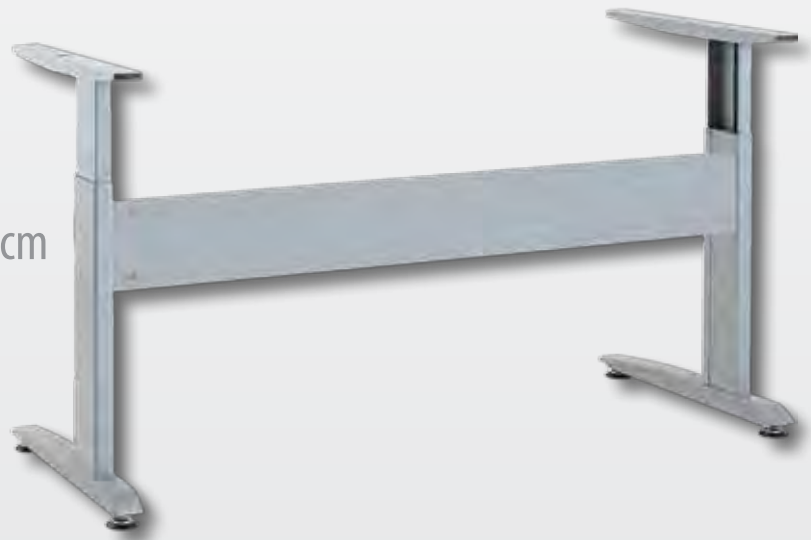

If ConSet front panels are required then it may be possible to order these with the frames depending for which country the frames will be delivered.

With the **back2back** cable beam the **501-15** becomes a "system" desk frame.

A single pair or many pairs of desks can be set up in a row with data and power cables running through the whole row. The end plate of the cable tray can also be used for mounting a screen lengthways between each pair of desks.

Desk manufacturers who stock **501-15**

2 legged frames can make their own version of this "**back2back**" cable tray system.



ConSet will be pleased to provide technical drawings to assist.





66-118 cm

Simplicity and elegance define the **501-17**. Sleek modern castors provide mobility when needed and the flip down cable tray offers practical convenience. A very popular choice at a very affordable price. The maximum frame capacity is 80 kg. [See specifications on pages 18-19.](#)

Frames	Item no.	Colour	Width
	501-17 7S096	Silver	96 cm
	501-17 7S156	Silver	156 cm



501-23

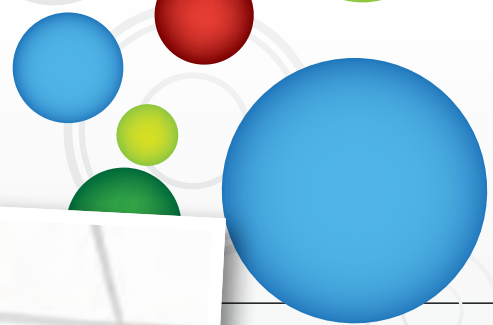

66-118 cm

Strong and stylish.
501-23 has telescopic length to suit many top sizes.
 The symmetrical design makes the frame excellent for meeting tables.
 Optional 3 column versions for extra long tables and L-shapes.
 Maximum frame capacity is 200 kg.
 See specifications on pages 18-19.

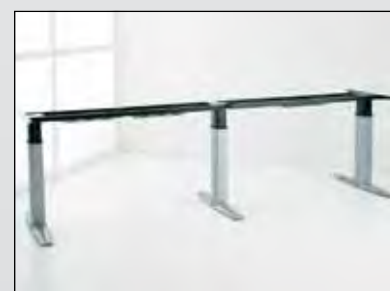

Frames	Item no.	Colour	Width
	501-23 7S200	Silver	136-200
	501-23 7S190-190A	Silver	145-190
	501-23 7S400K	Silver	280-400

About ConSet / General information

ConSet – a Danish company

ConSet was founded in May 2000 in a basement in Skjern, Denmark, and our basic philosophy was that ergonomics should not be expensive.

We began with the idea to develop and manufacture high quality electric height adjustable desks and to make them affordable so more people could experience the benefits of sit/stand desks.

The company has succeeded well and now has distribution and subsidiaries throughout the world. ConSet at its core is an engineering company that develops the products down to the smallest component. Since every component of a ConSet desk is developed and produced by the company including our patented drive system we are able to control our costs and achieve our goal.

Quality, consistency, value and support is what you will experience with ConSet at every level of our organization.

Environment

At ConSet we think it is important to minimize environmental impacts. We want to take responsibility for ensuring that our products are made respecting the environment. We do this in several ways:

- All electronic components meet **RoHS** framework for the reduction of hazardous substances in electronics, whereby the environmental impact is minimized.
- Through **Elretur** (Denmark), we ensure that electronic waste is managed environmentally under the WEEE directive. All ConSet products covered by the WEEE Directive are marked with the symbol .
- Several of our products are tested and comply with the demands in:
 - **ANSI/BIFMA X7.1 Standard for Formaldehyde and tvoc Emissions**
 - **ANSI/BIFMA e3-2012 Sec 7.6.1 & 7.6.2**
- From January 2010 a new law concerning standby consumption took effect. All our sit/stand frames meet the legal requirements for this.

Read more about the environment on www.conset.com

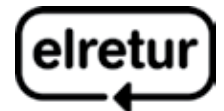

CE marking

All ConSet electric height adjustable desk frames are CE marked in collaboration with *the Technological Institute in Denmark*. CE marking is a requirement for height adjustable desk frames and it allows you to be sure that the producer has been through all aspects of security risks.

Our power supply units are also GS-tested (German standard).



Product Approvals

All ConSet products meet the necessary requirements within the following relevant categories:

Dimensional requirements:

EN 527-1: Office furniture – Workplaces and desks – Part 1: Dimensions

This means that the products meet all requirements for a healthy working environment, ie. leg room, height, depth, etc.

Strength, durability and stability:

EN 527-2: Office furniture – Workplaces and desks – Part 2: Mechanical safety requirements

A product standard that ensures that the tables meet all requirements for physical exertion and that all mechanical safety requirements are adhered to.

EN 527-3: Office furniture – Workplaces and desks – Part 3: Methods of test for the determination of the stability and the mechanical strength of the structure

Methods of testing for the determination of the stability and mechanical strength of the structure. A standard for product approval, where the product goes through a variety of tests to comply with the requirements of EN 527-2.

For desks these are technically focused on the strength of horizontal and vertical loading, fatigue and tipping.

Guarantee

The guarantee is valid from the date, you have purchased the product from your dealer.

Parts only against manufacturing defect. Electrical / mechanical parts: 2 years, Other parts: 5 years.

ConSet A/S reserves the right to change design and specifications without notice.

Desk frame specifications

Page	Product photo	Dimensional drawing () = depth of frame top support	Item no.	Colour	Frame height min./max. (cm)*	Maximum speed (mm/sec.)	Maximum capacity (kg)	Frame weight (kg)	Qty. per pallet
11		 58 (41) 94 (75)	501-77S 501-77B	Silver Black	66-118	25	50	30	20
13		 42 (41) 75	501-77SWS 501-77BWS	Silver Black	66-118	25	50	32	20
9		 49 (47) 120 (90)	501-197S120 501-197B120	Silver Black	66-118	28	100	26	15
8		 64 (47) 95 (90)	501-197S095 501-197B095	Silver Black	66-118	28	100	26	15
10		 50 (45) 60 (35)	501-197S060 501-197B060	Silver Black	66-118	28	100	24	15
12		 53 (47) 90	501-197SWS 501-197BWS	Silver Black	66-118	28	100	19	15
3		 59 140	501-111S138H 501-111B138H	Silver Black	63-120	28	100	39	15
3		 116 / 156 / 196 73 (73)	501-111S116 501-111B116 501-111S156 501-111B156 501-111S196 501-111B196	Silver Black Silver Black Silver Black	63-120	28	150	46 50 54	15
14		 Up to 180 cm 63 (63)	501-157SXXX 501-157WXXX	Silver White	66-118	25	65	20	48
15		 96 / 156 72 (63)	501-177S096 501-177S156	Silver Silver	66-118	25	80	28 31	27
2		 116 / 126 / 136 / 146 / 156 / 166 / 176 70 (66)	501-497S176 501-497B176 501-497W176	Silver Black White	63-123	32	100	24	28
16		 136-200 78 (63)	501-237S200	Silver	66-118	28	200	45	15
16		 280-400 78 (66)	501-237S400K	Silver	66-118	28	200	70	15

Desk frame specifications

Page	Product photo	Dimensional drawing () = depth of frame top support	Item no.	Colour	Frame height min./max. (cm)*	Maximum speed (mm/sec.)	Maximum capacity (kg)	Frame weight (kg)	Qty. per pallet
4			501-25 7S084 501-25 7S133 501-25 7S152 501-25 7S172	Silver Silver Silver Silver	66-116	25	80	26 29 30 31	20
6			501-27 7S084 501-27 7S133 501-27 7S152 501-27 7S172	Silver Silver Silver Silver	54-119	32	100	26 29 30 31	24
5			501-29 7S084 501-29 7S133 501-29 7S152 501-29 7S172	Silver Silver Silver Silver	63-130	32	100	31 34 35 36	20
7			501-32 7S084 501-32 7S133 501-32 7S152 501-32 7S172	Silver Silver Silver Silver	66-116	25	80	26 29 30 31	20
2			501-49 7S176-196A 501-49 7B176-196A 501-49 7W176-196A	Silver Black White	63-123	32	90	35	28
3	 Can be assembled right hand and left hand		501-11 1S156-156A 501-11 1B156-156A 501-11 1S196-196A 501-11 1B196-196A	Silver Black Silver Black	63-120	28	150	73 80	15
16			501-23 7S190-190A	Silver	66-118	28	200	63	15
14			501-15 7SXXX+ 501-15 XSXXXA 501-15 7WXXX+ 501-15 XWXXXA	Silver White	66-118	25	60	30	48
4	 Can be assembled right hand and left hand		501-25 7S152-115A 501-25 7S152-152A 501-25 7S172-172A	Silver Silver Silver	66-116	25	70	39 41 43	20
6	 Can be assembled right hand and left hand		501-27 7S152-115A 501-27 7S152-152A 501-27 7S172-172A	Silver Silver Silver	54-119	32	90	39 41 43	24
5	 Can be assembled right hand and left hand		501-29 7S152-115A 501-29 7S152-152A 501-29 7S172-172A	Silver Silver Silver	63-130	32	90	45 47 49	20
7	 Can be assembled right hand and left hand		501-32 7S152-115A 501-32 7S152-152A 501-32 7S172-172A	Silver Silver Silver	66-116	25	70	39 40 42	20

* Height range is to underside of worktop (the top of the frame). For all options and accessories see www.conset.com

ConSet

ConSet A/S
Industrivej 23
6900 Skjern, Denmark
Phone: +45 96 80 00 80
Fax: +45 96 80 00 81
www.conset.com
conset@conset.com